

THE METHOD OF EXPRESSING THE UNCERTAINTY OF DYNAMIC MEASUREMENTS

Vasilevskiy O. M., Didych V. M.

INTRODUCTION

To correctly assess the reliability of dynamic measurement results, it is necessary to demonstrate quantitative values of the quality of such measurements^{1,2}. Without knowing these values it is impossible to compare the results of dynamic measurements with each other or with the reference value. Obviously, there is a need to develop methods for assessing the qualitative characteristics of dynamic measurements. The task is complicated by the fact that in the course of dynamic measurements it will be necessary to take into account the transient modes of measuring devices (MD), during which the signal at the output will change significantly^{3,4}. Such changes are due to the internal device of MD, consisting of a variety of different masses and springs, capacitances and inductances and other inertial elements, which in turn lead to the emergence of dynamic uncertainty. Static MD conversion equation is not applicable in dynamic mode. Therefore, to describe the relationship between the output data $y(t)$ and the input values $x(t)$ of the measuring devices, it is necessary to go to differential equations⁵.

This research was conducted into the basic metrological characteristics displayed when developing new designs of measurement means for the

¹ ISO/IEC 17025:2005, *General requirements for the competence of testing and calibration laboratories* (Geneva, Switzerland, ISO, 2005), 28 p.

² Vasilevskiy O.M. Methods of determining the recalibration interval measurement tools based on the concept of uncertainty, *Tekhn. Elektrodin.* 6, 81 (2014).

³ S. Eichstädt, A. Link, C. Elster, Dynamic Uncertainty for Compensated Second-Order Systems, *Sensors*, 10, 7621 (2010).

⁴ Vasilevskiy O.M. Metrological characteristics of the torque measurement of electric motors. *International Journal of Metrology and Quality Engineering*, 8, 7 (2017).

⁵ S. Eichstädt, C. Elster, I. M. Smith and T. J. Esward, Evaluation of dynamic measurement uncertainty – an open-source software package to bridge theory and practice, *J. Sens. Sens. Syst.*, 6, 97–105 (2017).

evaluation of physical quantities, which is seen to be a crucial issue in science, the solution helping to ensure the uniformity of measurements and the identification of core and additional errors (uncertainties) in the measurement of a given type of measurement means.

Therefore, the scientific task of creating methods for estimating the uncertainty of dynamic measurements that would meet international requirements for evaluating the characteristics of measurement quality remains relevant.

1. Basic theoretical information

In case the equation of the measuring transducer is represented in the form

$$Y = K_C X, \quad (1)$$

where X is input signal which describes the measured value of the physical quantity; K_C is the coefficient of the conversion of the measuring device and Y is output signal which describes the measurement result, the mathematical expectation for the input signal will be equal to $M[X]$, and the mathematical expectation of the output signal will be equal to

$$M[Y] = K_C M[X], \quad (2)$$

where $M[Y]$ and $M[X]$ are the corresponding mathematical expectations of the output and input signals of the measuring device, respectively⁶.

The spectral density of the input signal $X(t)$ has the form⁷

$$H_X(\omega) = \lim (2T)^{-1} |X(j\omega)|^2 \text{ when } T \rightarrow \infty, \quad (3)$$

where $X(j\omega)$ is the Fourier image obtained by replacing the value in the operand of the image $X(s)$ by the values of s for $j\omega$; T is the time of observation; $\omega = 2\pi f$.

⁶ Vasilevskyi O.M., Yakovlev M.Yu., Kulakov P.I. Spectral method to evaluate the uncertainty of dynamic measurements, *Tekhn. Elektrodin.* 4, 72 (2017).

⁷ Gihan Gomah, A traceable time interval measurement with a reduced uncertainty. *International Journal of Metrology and Quality Engineering*, 6, 301 (2015).

The expression for the spectral density of the output signal can be represented by the expression⁸

$$H_Y(\omega) = \lim(2T)^{-1} |Y(j\omega)|^2 \text{ when } T \rightarrow \infty. \quad (4)$$

The relationship between the images of the output and input values gives us an expression for the transfer function of the measuring device⁹

$$K_C(s) = \frac{Y(s)}{X(s)} = \frac{\sum_{k=0}^m B_k s^k}{\sum_{q=0}^n A_q s^q}, \quad (5)$$

where $Y(s)$, $X(s)$ are the operator images of $Y(t)$ output and $X(t)$ input signals, respectively; k , q are the order of the derivatives of Y and X , respectively; A_q , B_k are the coefficients of the differential equation.

Therefore, we can write that

$$H_Y(\omega) = |K_C(j\omega)|^2 H_X(\omega), \quad (6)$$

where $K_C(j\omega)$ is the frequency characteristic of the measuring transducer¹⁰.

The spectral density of the error signal, reduced to the input, will be equal to

⁸ Esward T.J., Elster C., Hessling J.P., Analysis of dynamic measurements: new challenges require new solutions, in *Proc. of XIX IMEKO World Congress on Fundamental and Applied Metrology* (2009).

⁹ Vasilevskiy O.M., Kulakov P.I., Ovchynnykov K.V., Didych V.M. Evaluation of dynamic measurement uncertainty in the time domain in the application to high speed rotating machinery. *International Journal of Metrology and Quality Engineering*, Volume 8, Article Number 25, 2017 (pages 9). DOI: 10.1051/ijmqe/2017019.

¹⁰ Oleksandr Vasilevskiy, Pavlo Kulakov, Dmytro Kompanets, Oleksander M. Lysenko, Vasyly Prisyazhnyuk, Waldemar Wójcik, Doszhon Baitussupov, A new approach to assessing the dynamic uncertainty of measuring devices, *Proceedings Volume 10808, Photonics Applications in Astronomy, Communications, Industry, and High-Energy Physics Experiments 2018*, 108082E.URL: <https://doi.org/10.1117/12.2501578>.

$$H_{\Delta X}(\omega) = \left| \frac{K_C(j\omega)}{K_C} - 1 \right|^2 H_X(\omega), \quad (7)$$

K_C – frequency characteristic of the measuring device for $\omega = 0$.

The dispersion of the output signal σ_Y^2 for dynamic measurements can be defined as the square root of the integral of the spectral density of the output signal over all frequencies

$$\sigma_Y = \pi^{-1/2} \left(\int_0^{\infty} H_Y(\omega) d\omega \right)^{1/2}. \quad (8)$$

Taking into account the equations (3) and (6) above, the dispersion of the output signal σ_Y^2 (8) can be represented on the basis of the spectral density of the input signal and the frequency characteristic of the measuring channel used (measuring means)

$$\sigma_Y = \pi^{-1/2} \left(T^{-1} \int_0^{\infty} |K_C(j\omega)|^2 |X(j\omega)|^2 d\omega \right)^{1/2}, \quad (9)$$

where $|K_C(j\omega)|$ is the frequency response module of the measuring device, used for dynamic measurements¹¹.

Similarly, the variance of the error signal, reduced to the input, will be equal to

$$\sigma_{\Delta X} = \pi^{-1/2} \left(\int_0^{\infty} \left| \frac{K_C(j\omega)}{K_C} - 1 \right|^2 |X(j\omega)|^2 d\omega \right)^{1/2}. \quad (10)$$

¹¹ Vasilevskiy O. M. EVALUATION OF UNCERTAINTY OF THE RESULTS OF DYNAMIC MEASUREMENTS, CONDITIONED THE LIMITED PROPERTIES USED THE MEASURING INSTRUMENT. 9 International Workshop on Analysis of Dynamic Measurements. 2016. Berlin, Germany (9–10 November, 2016). URL: <http://mathmet.org/resources/DYNAMIC2016/Vasilevski,-Alexandre-Dynamic-uncertainty.pdf>.

The frequency response module of the measuring device is determined by the formula

$$|K_C(j\omega)| = (a^2(\omega) + b^2(\omega))^{1/2}, \quad (11)$$

where $a(\omega)$, $b(\omega)$ are respectively, the real and imaginary parts of the frequency response MD $K_C(j\omega)$ ¹².

The spectral function of the incoming signal $X(j\omega)$ is related to its time function $X(t)$ by the Laplace expression¹³

$$X(s) = \int_0^{\infty} X(t) e^{-st} dt. \quad (12)$$

When the input signal passes through the measuring device (measuring channel), distortions arise associated with the limited properties of the measuring channel and as a result, the main harmonics of the input signal under study appear pulsations ω_0 . To study the measurement uncertainty, a certain frequency ω_0 is allocated from the entire frequency spectrum, which is associated with the limited nature of the measuring device.

For a finite time interval, the infinity sign may be replaced by the total observation time T .

The dynamic error of the measuring transducer, brought to the input, in the time domain can be represented by the expression

$$\Delta X(t) = \pi^{-1/2} \int_0^{\infty} \sigma_{\Delta X} e^{j\omega t} d\omega = \pi^{-1/2} \left[\int_0^{\infty} \sigma_{\Delta X} \cos(\omega t) d\omega + j \int_0^{\infty} \sigma_{\Delta X} \sin(\omega t) d\omega \right]. \quad (13)$$

¹² Vasilevskiy O.M. A frequency method for dynamic uncertainty evaluation of measurement during modes of dynamic operation, *Int. J. Metrol. Qual. Eng.*, 6, 202, (2015).

¹³ Bartoli C., Beug M.F., Bruns T., Elster C., Esward T., Klaus L., Knott M., Kobusch M., Saxholm S. and Schlegel C., *Traceable dynamic measurement of mechanical quantities: objectives and first results of this European project*, *Int. J. Metrol. Qual. Eng.*, 3, 3, (2012), 127–135.

Consequently, the dynamic error that occurs due to the limited properties of the measuring device can be estimated in the time domain based on the model equation of the spectral function of the input signal and the frequency response of the measurement (13).

It is obvious that expression (13) consists of real and imaginary parts, and when evaluating an error, it is necessary to analyze the amplitude value of the dynamic error, expression (13) needs to be converted to the form

$$|\Delta X(t)| = \left[\left(\int_0^{\infty} \pi^{-1/2} \sigma_{\Delta X} \cos(\omega t) d\omega \right)^2 + \left(\int_0^{\infty} \pi^{-1/2} \sigma_{\Delta X} \sin(\omega t) d\omega \right)^2 \right]^{1/2}. \quad (14)$$

When, for instance, prior knowledge about the amplitude of the frequency spectrum of the measurand is available in terms of a frequency function, then equation (14) can be rewritten in the form

$$|\Delta X(t)| = \left[\left(\int_0^{\pi F_s} \pi^{-1/2} \sigma_{\Delta X} \cos(\omega t) d\omega \right)^2 + \left(\int_0^{\pi F_s} \pi^{-1/2} \sigma_{\Delta X} \sin(\omega t) d\omega \right)^2 \right]^{1/2}, \quad (15)$$

with $F_s=1/T_s$ the sampling frequency.

According to GUM¹⁴ Supplement 2, the uncertainty associated with the estimation error is then given as the variance of the corresponding rectangular probability distribution, i.e. the dynamic uncertainty of the measuring device can be estimated from the formula

$$u_D(t) = \sqrt{\left(\int_0^{\pi F_s} \pi^{-1/2} \sigma_{\Delta X} \cos(\omega t) d\omega \right)^2 + \left(\int_0^{\pi F_s} \pi^{-1/2} \sigma_{\Delta X} \sin(\omega t) d\omega \right)^2} / \sqrt{3}. \quad (16)$$

To confirm the proposed theoretical basis for estimating the dynamic uncertainty of measuring instruments, we will perform a study of the characteristics of the change in dynamic uncertainty by the example of a vibration acceleration measurement using an accelerometer.

¹⁴Evaluation of measurement data. *Guide to the expression of uncertainty in measurement*, JCGM 100, GUM 1995 with minor corrections, 1st edn. (2008).

2. Experimental research

The differential equation describing the dynamic relationship of the input and output values of the vibration acceleration measuring transducer has the form

$$\frac{d^2 X_s(t)}{dt^2} + 2h \frac{dX_s(t)}{dt} + h_k^2 X_s(t) = \frac{F_0}{m} \cos(\omega_0 t), \quad (17)$$

where $F(t) = F_0 \cos(\omega_0 t)$ is the harmonic forced power of the oscillation of the surface of the object (input value); F_0 is the force amplitude; ω_0 is the angular frequency of forced power; $X_s(t)$ represents the the mechanical vibrations of the inertial mass; m is the mass of the accelerometer; c is the damping variable; k is the equivalent rigidity of the piezoelements, $h = c/2m$ is the damping coefficient; $h_k = \sqrt{k/m}$ is the critical value damping coefficient¹⁵.

The accelerometer is located on the electrospindle of the engine and performs spot metering of the vibration in the frequency¹⁶ range from 6 kHz to 10 kHz, which is created by the operation of the roller bearings (Fig. 1)¹⁷.

The electrospindle is a mechanical system consisting of a metal spindle body, an mounting system to asynchronous motor, rolling bearings and a shaft that is mechanically connected to the motor rotor and designed for operation at ultrahigh angular speeds (Fig. 1). It must provide a high peak power and constant action power, maximum radial and axial stiffness, maximum rotation speed, high demands on accuracy and performance. The use of electrospindles with an integrated motor for high-speed machining is possible for a number of practical applications where the required spindle speed can be 8000 rpm.

¹⁵ Vasilevskiy O.M., Kulakov P.I., Dudatiev I.A., Didych V.M., Kotyra Andrzej, Suleimenov Batyrbek, Assembay Azat, Ainur Kozbekova Ainur, Vibration diagnostic system for evaluation of state interconnected electrical motors mechanical parameters, Proc. *SPIE 10445*, Photonics Applications in Astronomy, Communications, Industry, and High Energy Physics Experiments 2017, 104456C (August 7, 2017); doi:10.1117/12.2280993.

¹⁶ Podzharenko V.O., Vasilevskiy O. M. Diagnostics of technical condition of electromechanical systems for the logarithmic decrement. *Proceedings of Donetsk National Technical University*. 88, 138–144 (2005).

¹⁷ Vasilevskiy O.M. Means for measuring the dynamic torque electric motors and an analysis of its accuracy, *Vymiriuvalna tekhnika ta metrolohiia*, 73, 52–56 (2012).

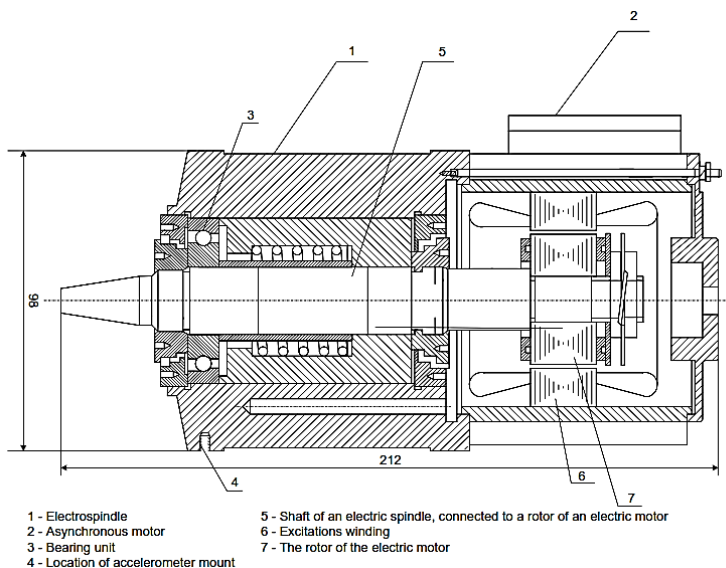

Fig. 1. Constructive drawing electrospindle

One of the most critical components of any high-speed electrospindle is the bearing system. The electrospindle should have high speeds of rotation, transfer the necessary torque and power to the tool, have good load capacity and a long service life. Bearings must meet all these requirements.

To ensure trouble-free operation, regular maintenance and diagnosis of bearing assemblies are necessary to determine the incipient defects. These defects are determined at frequencies from 6 to 10 kHz¹⁸. Therefore, the measurement of vibration in this frequency range is an actual scientific task, which allows to determine the incipient defects at early stages and to perform maintenance of the bearing units according to actual need¹⁹.

To study the dynamic characteristics of measuring device that are used for dynamic measurements, one must resort to differential equations

¹⁸ IEC 60747-14-4:2011, Semiconductor devices – Discrete devices – Part 14-4: Semiconductor accelerometers (IEC, Switzerland, 2011).

¹⁹ Vasilevskiy O.M., Calibration method to assess the accuracy of measurement devices using the theory of uncertainty. *International Journal of Metrology and Quality Engineering*. 2014, 5.04: 403.

describing the dynamic relationship between output and input quantities. Therefore, the frequency characteristics of measuring devices are very convenient for compiling a model equation for dynamic measurements and estimating uncertainty, which is caused by the limited properties of measuring devices in the dynamic mode of operation, with sinusoidal input signals. In addition, in the frequency domain, it is possible to investigate a complex sinusoidal signal, which is vibration.

The equivalent circuit of the measuring channel of vibration acceleration²⁰ shown in Figure 2.

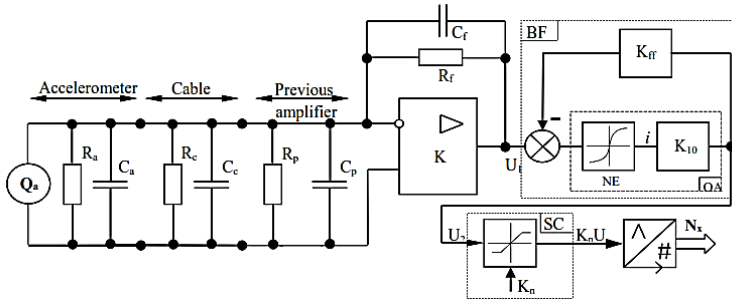

Fig. 2. Equivalent circuit measuring channel of vibration

In figure 2 is designated: Q_a – electric charge; R_a – accelerometer resistance; C_a – accelerometer capacity; R_c – resistance of the connecting cable; C_c – capacity of the connecting cable; R_p – resistance of the input circuit of the preamplifier; C_p – capacity of the input circuit of the preamplifier; R_f – resistance of the feedback loop; C_f – capacity of the feedback loop; K – preamplifier; U_1 – output voltage of preamplifier; BF – bandpass filter; NE – non-linear element; K_{10} – transfer coefficient BF; K_{ff} – feedback factor BF; OA – operational amplifier; SC – scale converter; K_n – amplification factor SC; N_x – code analog to digital converter.

²⁰ Vasilevskiy O.M., Kucheruk V.Y., Bogachuk V.V., Gromaszek K., Wójcik W., Smailova S., Askarova N. The method of translation additive and multiplicative error in the instrumental component of the measurement uncertainty. *Proc. SPIE 10031, Photonics Applications in Astronomy, Communications, Industry, and High-Energy Physics Experiments*, 2016, 1003127 (September 28, 2016). DOI:10.1117/12.2249195.

The uncertainty budget of the constituent elements of the measuring channel of the acceleration in relative units is shown in Table 1. On the basis of an experimental study of the uncertainty budget of the measurement channel of the vibration acceleration (Tab. 1), a the relative value of the combined standard uncertainty was calculated without taking into account the dynamic component of the uncertainty, which is 0.36%.

Table 1

**Uncertainty budget of the constituent elements
of the measuring channel of vibration acceleration**

| Elements | Value of relative uncertainty, % | The expanded uncertainty (coverage factor 1.96 at confidence level 95%), % | Distribution |
|---|----------------------------------|--|-----------------------|
| Accelerometer | 0.3 | 0.59 | Uniform (rectangular) |
| Preliminary charge amplifier | 0.02 | 0.04 | Uniform (rectangular) |
| Bandpass filter | 0.2 | 0.39 | Uniform (rectangular) |
| Scale converter | 0.01 | 0.02 | Uniform (rectangular) |
| ADC | 0.005 | 0.01 | Uniform (rectangular) |
| Background noise | $2.14 \cdot 10^{-6}$ | $4.19 \cdot 10^{-6}$ | Normal |
| The combined standard uncertainty (\tilde{u}_s) | 0.36 | 0.71 | Normal |
| Mean value | | | 2.93 m/s^2 |

The transfer function of the measuring device will take the form of

$$H(s) = \frac{K_{MM}}{s^2 + 2hs + h_k^2}, \quad (18)$$

where K_{MM} is the coefficient of proportionality of the measuring channel of vibration acceleration.

Turning to the domains of frequency and separating the real and imaginary parts, we obtain an expression for the module of the frequency characteristics of the measuring device for vibration acceleration

$$|K_C(j\omega)| = \left| \frac{K_{MM}}{(j\omega)^2 + 2h(j\omega) + h_k^2} \right| = \left[\frac{K_{MM}}{\omega^4 - 2\omega^2 h_k^2 + 4\omega^2 h^2 + h_k^4} \right]^{1/2}, \quad (19)$$

$$K_C = \frac{mK_{MM}}{k}. \quad (20)$$

The input signal $F_0 m^{-1} \cos(\omega_0 t)$ of vibration acceleration has the form of

$$X(j\omega) = j\omega F_0 (\omega_0^2 + (j\omega)^2)^{-1} m^{-1}, \quad (21)$$

where ω_0 is the cyclic frequency input vibration acceleration, which ranges from 6 to 10 kHz that is, with a minimum value of 18,849.5 and the maximum value is 31,415.9 radians/second.

The main number of defects manifest themselves by excitation of high-frequency vibrations in the frequency range of 6-10 kHz and it is for this reason that the boundary values of the range (less than 6 kHz, greater than 10 kHz) are chosen as the minimum and maximum input harmonic signals ω_0 , which is included in equation (14).

The module image of the input vibration acceleration is written as

$$|X(j\omega)| = \omega F_0 (\omega_0^2 - \omega^2)^{-1} m^{-1}. \quad (22)$$

From source literature²¹, it is known that the amplitude of forced harmonic power F_0 is $3 \cdot 10^{-4}$ m. The mass of the accelerometer²² is $m = 4 \cdot 10^{-2}$ kg. The damping variable for the piezoelectric accelerometers is equal to 0.5, equivalent rigidity of the piezoelements is $k = 2$, and the minimum observation time $T = 300$ s. The proportionality factor or gain K_{MM} of the measuring channel of the vibration acceleration is 10^5 .

²¹ T. Bruns, M. Kobusch, Traceability of dynamic force and torque calibrations by means of laser-Dopplerinterferometry, Proc. SPIE 5503, 602–607 (2004).

²² Broch J.T. Mechanical Vibrations and Shock measurements. 2nd edition. Brüel & Kjær (1984).

Substituting the resulting values of the module of the frequency characteristics (19), (20) and the image of the input signal (22) in equation (10), we obtain an expression for the evaluation of the variance of the error signal of vibration acceleration in the spectral area, reduced to the input

$$\sigma_{\Delta X} = \pi^{-1/2} \left(\int_0^{\infty} \frac{\omega F_0 \left[\left(k(h_k^2 - \omega^2) - m(h_k^2 - \omega^2)^2 - 4m\omega^2 h^2 \right)^2 + 4k^2 \omega^2 h^2 \right]}{2Tm(\omega_0^2 - \omega^2) \left(m(h_k^2 - \omega^2)^2 + 4m\omega^2 h^2 \right)} d\omega \right)^{1/2}. \quad (23)$$

To represent the characteristics of the changes in the uncertainty in the dynamic measurement vibration acceleration in the time domain, which is caused by the inertial properties of the measuring transducer in its dynamic mode we must express a Fourier expression for inverse transformation in the form of (15).

Since expression (15) consists of real and imaginary parts, and in assessing the uncertainty we are interested in the amplitude value of dynamic uncertainty, expression to evaluate the dynamic uncertainty (16) can be written as

$$u_D(t) = \left[\left(\int_0^{\pi F_s} \pi^{-1/2} \sigma_{\Delta X} \cos(\omega t) d\omega \right)^2 + \left(\int_0^{\pi F_s} \pi^{-1/2} \sigma_{\Delta X} \sin(\omega t) d\omega \right)^2 \right]^{0.5} / \sqrt{3}. \quad (24)$$

Equation (24) was solved using the Maple 12 mathematical package, taking into account expression (23). With a given minimum frequency of the input signal of vibration acceleration of 6 kHz and a given observation time of 300 s, the value of dynamic uncertainty is 0.156 m/s² (Fig. 3). If the observation period increased to 600 s with a vibration acceleration input frequency of 6 kHz, the dynamic uncertainty value decreased to 0.116 m/s² (Fig. 4). The nominal value of the signal of the vibration acceleration of the bearings of the motor of the motor is 2.93 m/s². The characteristics of the change in the dynamic uncertainty of the vibration acceleration measurement as a function of the time variable obtained using the Maple 10 mathematical package are presented in Figures 1 and 2 with a minimum frequency of the input signal of vibration acceleration of 6 kHz with an observation time of 300 s and 600 s, respectively.

Substituting the values of the above shock coefficients into expressions (23) and (24), we obtain the amplitude value of the dynamic

uncertainty of the measurement of the vibration acceleration, which is 0.088 m/s^2 , while the frequency of the input signal is the vibration acceleration of 10 kHz, and the time of observation of the vibration acceleration $T = 300 \text{ s}$ (Fig. 5). If the observation time increases to 600 s at the same frequency of the input vibration acceleration signal, the value of dynamic uncertainty decreases to 0.064 m/s^2 (Fig. 6). The characteristics of the change in the dynamic uncertainty of measurement as a function of the time variable obtained using the Maple 12 mathematical package are presented in Figures 3 and 4 with a maximum frequency of the input vibration acceleration signal of 10 kHz with an observation time of 300 s and 600 s, respectively.

Based on the proposed spectral method for estimating the uncertainty of dynamic measurements, an estimate was obtained of the uncertainty of dynamic measurements of the vibration acceleration of the electric motor spindle roller bearings. The proposed approach is based on mathematical models of the spectral function of the input signal of the vibration acceleration and frequency characteristics of the measuring transducer to accelerate the vibration. This in turn makes it possible to take into account the values of dynamic uncertainties when estimating the total uncertainty of measuring the vibration acceleration.

To calculate the maximum relative value of the uncertainty of the dynamic measurement of vibration acceleration, we divide the obtained maximum value of dynamic uncertainty 0.156 m/s^2 (Fig. 3) by the nominal value of the vibration acceleration of $\bar{X} = 2.93 \text{ m/s}^2$, as a result of which we obtain²³

$$\tilde{u}_D = \frac{u_D(t)}{\bar{X}} 100\% = \frac{0.156}{2.93} 100\% = 5.32\%. \quad (25)$$

When calculating the relative value of the uncertainty of the dynamic measurement of vibration acceleration from formula (23) and (24) for the frequency of 6 kHz and the observation time 600 s, we obtain 3.96% (Fig. 4). At a frequency of 10 kHz and an observation time of 300 s (Fig. 5), we get the relative dynamic uncertainty of the measurement of

²³Vasilevskiy O.M., Kulakov P.I., Didych V.M. Technique Of Research Uncertainty Dynamic Measurements Of Vibration Acceleration Of Rotating Machines. *IOSR Journal of Electrical and Electronics Engineering (IOSR-JEEE)*. 2016. Volume 11. Issue 5. Ver. III. PP. 34-39. DOI: 10.9790/1676-1105033439.

3 %. At a frequency of 10 kHz and an observation time of 600 s (Fig. 6), we get the relative dynamic uncertainty of the measurement of 2.18%.

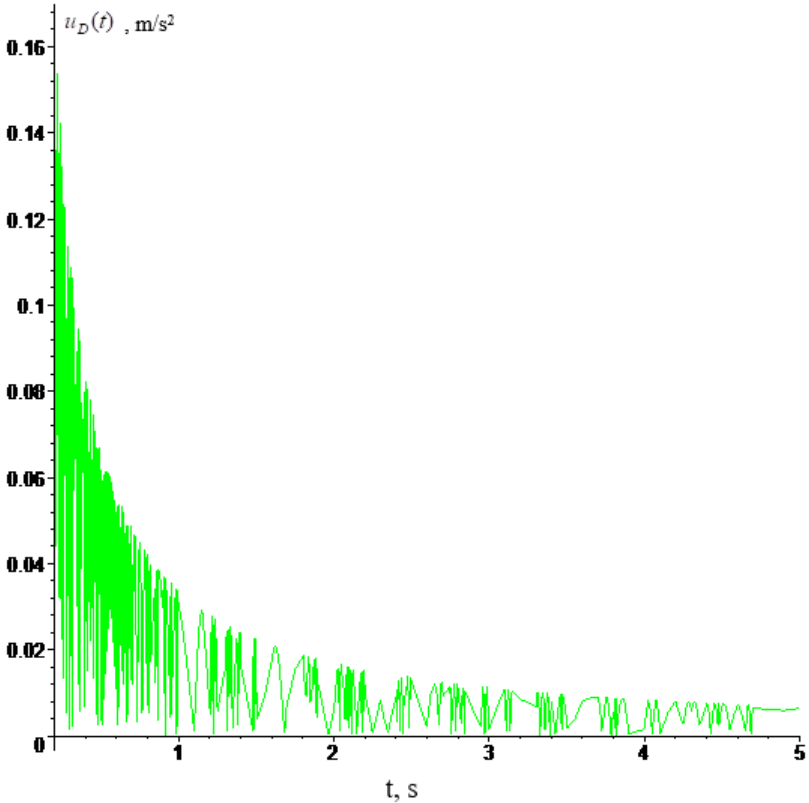

Fig. 3. Uncertainty of dynamic measurement of vibration acceleration at a frequency of 6 kHz and observation time of 300s

The uncertainty budget of the dynamic measurement of the vibration acceleration for the observation time of 300 s and 600 s at frequencies of 6 and 10 kHz is shown in Table 2. The maximum value of dynamic uncertainty is 5.32% at a frequency of 6 kHz at a observation time of 300 s (Tab. 2).

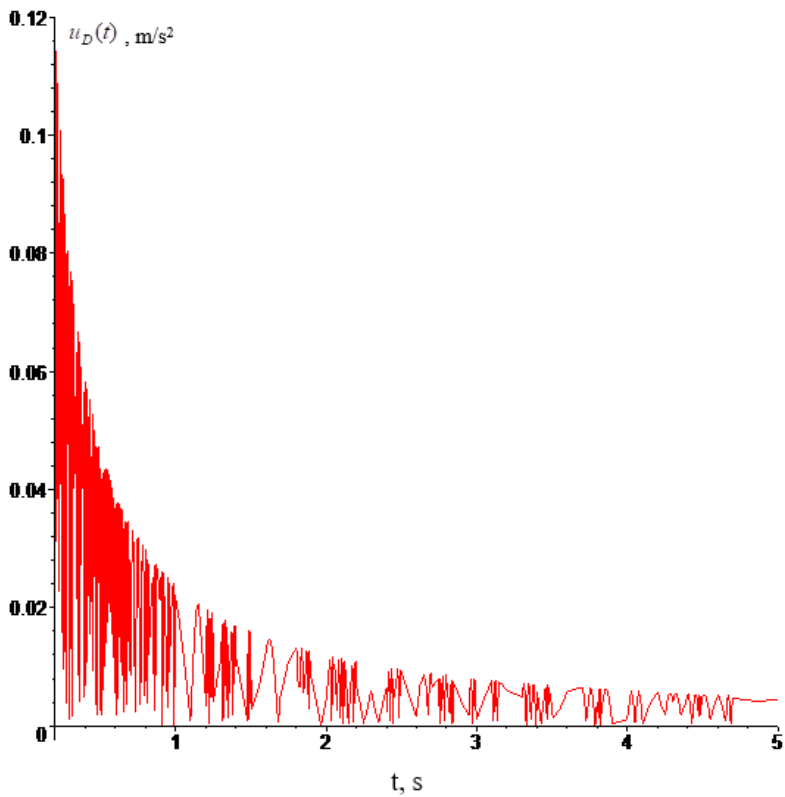

Fig. 4. Uncertainty of dynamic measurement of vibration acceleration at a frequency of 6 kHz and observation time of 600s

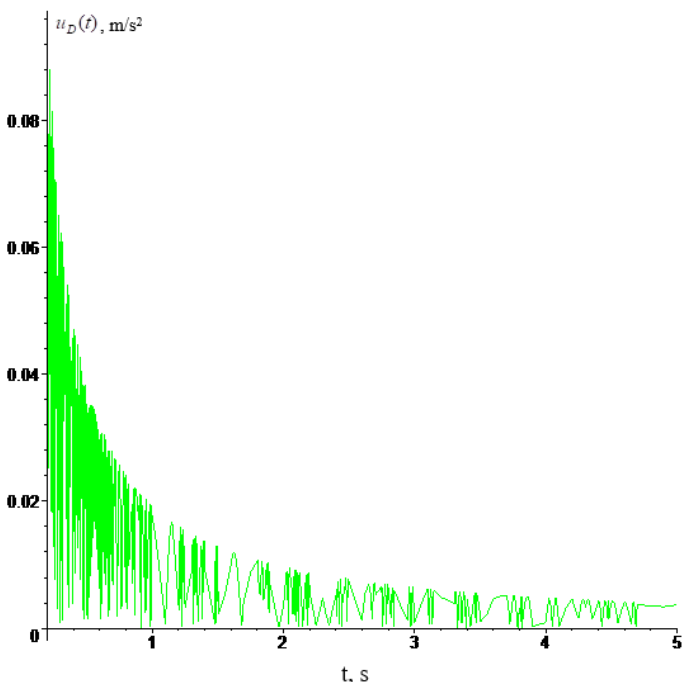

Fig. 5. Uncertainty of dynamic measurement of vibration acceleration at a frequency of 10 kHz and observation time of 300s

The relative combined uncertainty measurement of the vibration acceleration, taking into account the relative dynamic uncertainties \tilde{u}_D (Tab. 2) and the relative combined standard uncertainty \tilde{u}_s (Tab. 1), is calculated by the formula

$$\tilde{u}_C = \sqrt{\tilde{u}_D^2 + \tilde{u}_s^2} = \sqrt{5.32^2 + 0.36^2} = 5.33\% . \quad (26)$$

Thus, the maximum value of the relative combined uncertainty of the vibration acceleration measurement is 5.33% with an observation time of 300 s and a frequency of 6 kHz. At a monitoring time of 600 s at a frequency of 6 kHz, the combined uncertainty value is 3.98%. At a frequency of 10 kHz at a observation time of 300 s, the combined

uncertainty is 3.02% and at a observation time of 600 s at the same frequency of 2.21%.

Table 2

**Uncertainty budget of the constituent elements
of the measuring channel of vibration acceleration**

| Quantity | Mean value, m/s^2 | Frequency of the study, kHz | Observation time, s | Value of dynamic uncertainty, m/s^2 | The expanded dynamic uncertainty (coverage factor 1.96 at confidence level 95%), m/s^2 | Value of relative dynamic uncertainty, % |
|----------------------------|---------------------|-----------------------------|---------------------|---------------------------------------|--|--|
| The vibration acceleration | 2.93 | 6 | 300 | 0.16 | 0.32 | 5.32 |
| | | 6 | 600 | 0.12 | 0.24 | 3.96 |
| | | 10 | 300 | 0.09 | 0.18 | 3 |
| | | 10 | 600 | 0.06 | 0.12 | 2.18 |

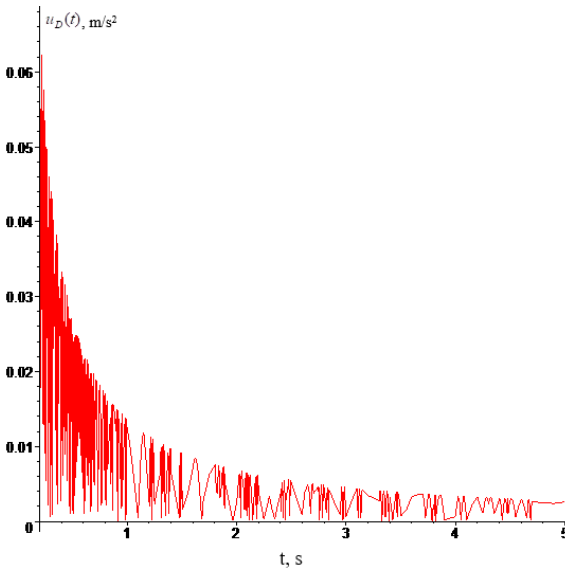

Fig. 6. Uncertainty of dynamic measurement of vibration acceleration at a frequency of 10 kHz and observation time of 600s

CONCLUSIONS

The spectral method for estimating the uncertainty of dynamic measurements proposed by the authors allows calculating the amplitude values of dynamic uncertainties without contradicting international requirements for assessing the quality of measurements – the concept of uncertainty. In turn, this approach helps to ensure uniformity of measurements, which makes it possible to compare the results of dynamic measurements carried out by various measuring instruments and to conduct tests by various laboratories in leading countries. The proposed method was tested in assessing the dynamic uncertainty of measuring the vibration acceleration of a roller bearing of an electric motor, which proved its validity and efficiency.

The described approach to estimating the dynamic uncertainty of measuring instruments can be used for any measuring instruments that are characterized by dynamic components of any type.

SUMMARY

A spectral method for estimating the dynamic uncertainty of measuring instruments based on a mathematical model of the frequency characteristic of a measuring instrument and a model of the spectral function of an input signal is presented. The model equation for estimating the amplitude value of the dynamic measurement uncertainty is obtained, which is caused by the limited properties of the measuring devices when a measuring signal passes through it in dynamic operation modes. A mathematical simulation of the characteristic of the dynamic uncertainty variation during the passage of a measuring signal through a measuring transducer is performed using the dynamic model of a vibration transducer as an example. Thus, the maximum value of the relative combined uncertainty of the vibration acceleration measurement is 5.33% with an observation time of 300 s and a frequency of 6 kHz. At a monitoring time of 600 s at a frequency of 6 kHz, the combined uncertainty value is 3.98%. At a frequency of 10 kHz at a observation time of 300 s, the combined uncertainty is 3.02% and at a observation time of 600 s at the same frequency of 2.21%. It helps to ensure the uniformity of measurements and enables comparison of the results of dynamic measurements made by different measuring devices and testing by different laboratories of leading countries.

REFERENCES

1. ISO/IEC 17025:2005. General requirements for the competence of testing and calibration laboratories (Geneva, Switzerland, ISO, 2005), 28 p.
2. Vasilevskyi O.M. Methods of determining the recalibration interval measurement tools based on the concept of uncertainty. *Tekhn. Elektrodin.* 6, 81, 2014.
3. Eichstädt S., Link A., Elster C. Dynamic Uncertainty for Compensated Second-Order Systems. *Sensors.* 10, 7621 (2010).
4. Vasilevskyi O.M. *Metrological characteristics of the torque measurement of electric motors. International Journal of Metrology and Quality Engineering*, 8, 7, 2017.
5. Eichstädt S., Elster C., Smith I.M. and Esward T.J. Evaluation of dynamic measurement uncertainty – an open-source software package to bridge theory and practice, *J. Sens. Sens. Syst.*, 6, 97–105 (2017).
6. Vasilevskyi O.M., Yakovlev M.Yu., Kulakov P.I. Spectral method to evaluate the uncertainty of dynamic measurements. *Tekhn. Elektrodin.* 4, 72 (2017).
7. Gihan Gomah. A traceable time interval measurement with a reduced uncertainty, *International Journal of Metrology and Quality Engineering.* 6, 301 (2015).
8. Esward T.J., Elster C., Hessling J.P. Analysis of dynamic measurements: new challenges require new solutions, in *Proc. of XIX IMEKO World Congress on Fundamental and Applied Metrology* (2009).
9. Vasilevskyi O.M., Kulakov P.I., Ovchynnykov K.V., Didych V.M. Evaluation of dynamic measurement uncertainty in the time domain in the application to high speed rotating machinery. *International Journal of Metrology and Quality Engineering.* Volume 8, Article Number 25, 2017. DOI: 10.1051/ijmqe/2017019.
10. Oleksandr Vasilevskyi, Pavlo Kulakov, Dmytro Kompanets, Oleksander M. Lysenko, Vasyl Prisyazhnyuk, Waldemar Wójcik, Doszhon Baitussupov. A new approach to assessing the dynamic uncertainty of measuring devices. *Proceedings Volume 10808, Photonics Applications in Astronomy, Communications, Industry, and High-Energy Physics Experiments 2018*, 108082E. URL: <https://doi.org/10.1117/12.2501578>.
11. Vasilevskyi O.M. Evaluation of uncertainty of the results of dynamic measurements, conditioned the limited properties used the measuring instrume. 9 International Workshop on Analysis of Dynamic

Measurements. 2016. Berlin, Germany (9–10 November, 2016). <http://mathmet.org/resources/DYNAMIC2016/Vasilevski,-Alexsandre-Dynamic-uncertainty.pdf>.

12. Vasilevskiy O.M. A frequency method for dynamic uncertainty evaluation of measurement during modes of dynamic operation. *Int. J. Metrol. Qual. Eng.*, 6, 202, (2015).

13. Bartoli, M.F. Beug, T. Bruns, C. Elster, T. Esward, L. Klaus, A. Knott, M. Kobusch, S. Saxholm and C. Schlegel, *Traceable dynamic measurement of mechanical quantities: objectives and first results of this european project*, *Int. J. Metrol. Qual. Eng.*, 3, 3, (2012), 127–135.

14. Evaluation of measurement data. *Guide to the expression of uncertainty in measurement*, JCGM 100, GUM 1995 with minor corrections, 1st edn. (2008).

15. Vasilevskiy O.M., Kulakov P.I., Dudatiev I.A., Didych V.M., Kotyra Andrzej, Suleimenov Batyrbek, Assembay Azat, Ainur Kozbekova Ainur, *Vibration diagnostic system for evaluation of state interconnected electrical motors mechanical parameters*, *Proc. SPIE* 10445, Photonics Applications in Astronomy, Communications, Industry, and High Energy Physics Experiments 2017, 104456C (August 7, 2017); doi:10.1117/12.2280993.

16. Podzharenko V.O., Vasilevskiy O.M. *Diagnostics of technical condition of electromechanical systems for the logarithmic decrement*, Proceedings of Donetsk National Technical University, 88, 138–144 (2005).

17. Vasilevskiy O.M. Means for measuring the dynamic torque electric motors and an analysis of its accuracy. *Vymiriuvalna tekhnika ta metrolohiia*, 73, 52–56 (2012).

18. IEC 60747-14-4:2011, *Semiconductor devices – Discrete devices – Part 14-4: Semiconductor accelerometers* (IEC, Switzerland, 2011).

19. Vasilevskiy O.M., Calibration method to assess the accuracy of measurement devices using the theory of uncertainty. *International Journal of Metrology and Quality Engineering*. 2014, 5.04: 403.

20. Vasilevskiy O.M., Kucheruk V.Y., Bogachuk V.V., Gromaszek K., Wójcik W., SmailovaS., Askarova N., *The method of translation additive and multiplicative error in the instrumental component of the measurement uncertainty*, *Proc. SPIE* 10031, Photonics Applications in Astronomy, Communications, Industry, and High-Energy Physics Experiments, 2016, 1003127 (September 28, 2016). DOI:10.1117/12.2249195.

21. Bruns T., Kobusch M. Traceability of dynamic force and torque calibrations by means of laser-Dopplerinterferometry, Proc. SPIE 5503, 602–607 (2004).

22. Broch J.T. Mechanical Vibrations and Shock measurements. 2nd edition. Brüel & Kjær (1984).

23. Vasilevskiy O.M., Kulakov P.I., Didych V.M. Technique Of Research Uncertainty Dynamic Measurements Of Vibration Acceleration Of Rotating Machines // IOSR Journal of Electrical and Electronics Engineering (IOSR-JEEE). 2016. Vol. 11. Issue 5. Ver. III. PP. 34-39. DOI: 10.9790/1676-1105033439.

Information about authors:

Vasilevskiy O. M.,

Doctor of Engineering Sciences,

First Vice-Rector,

Professor of Department of Metrology and Industrial Automation

Vinnitsia National Technical University

95, Khmelnytskoye Shose, Vinnitsya, 21021, Ukraine

Didych V. M.,

Candidate of Technical Sciences,

Associate Professor of Department of Biophysics,

Informatics and Medical Equipment

Vinnitsia National Medical University named after M. I. Pirogov

56, Pirogova, Vinnitsa, 21018, Ukraine